

■ High Voltage Series Of Ceramic Chip Capacitors



◆ Feature

- * High voltage MLCC is a kind of special design MLCC that bases on the technology of general MLCC. This kind of MLCC has stable high voltage reliability and suitable to SMT. High voltage MLCC is widely applicable for many direct high voltage circuits in which it can improve the performance of the circuit.
- * There is high reliability on monolithic structure of laminated layers.
- * And its character of excellent soldering ability and soldering resistance ability is suitable for reflow soldering and peak soldering.
- * It includes high and stable capacitance
- * Executive Standard: GB/T 21041-2007 GB/T 21042-2007

◆ Application

- * Analog & Digital Modems
- * LAN/WAN Interface
- * Lighting Ballast Circuits
- * Voltage Multipliers
- * DC-DC Converters
- * Back-lighting Inverters

◆ How To Order

Size Code			Nominal Capacitance		Rated Voltage: V		Package Styles	
Size Code	(L×W) inch	(L×W) mm	Express Method	Actual Value	Express Method	Actual Value	Express Method	Package Styles
0402	0.04×0.02	1.00×0.50	0R5	0.5	201	20×10 ¹	B	Bulk Bag
0603	0.06×0.03	1.60×0.80	1R0	1.0	501	50×10 ¹	T	Taping Package
0805	0.08×0.05	2.00×1.25	102	10×10 ²	631	63×10 ¹		
1206	0.12×0.06	3.20×1.60	Note: the first two digits are significant; third digit denotes number of zeros; R=decimal point.		Note: the first two digits are significant; third digit denotes number of zeros; R=decimal point.			
1210	0.12×0.10	3.20×2.50						
1808	0.18×0.08	4.50×2.00						
1812	0.18×0.12	4.50×3.20						
2211	0.22×0.11	5.70×2.80						
2220	0.22×0.20	5.70×5.00						
2225	0.22×0.25	5.70×6.30						

Dielectric Code		Capacitance Tolerance			Terminal Material Styles	
Dielectric Code	Dielectric	Code	Tolerance	Note		
CG	C0G	A	±0.05pF	These Capacitance tolerance A, B, C, D are just applicable the capacitance that equals to or less than 10pF.	Termination Styles	Express Method
B	X7R	B	±0.10pF		Copper Solderable Termination	C
		C	±0.25pF		Nickel Barrier Termination	N
		D	±0.50pF			
		F	±1%			
		G	±2%			
		J	±5%			
		K	±10%			
		M	±20%			
		S	-20% +50%			
		Z	-20% +80%			

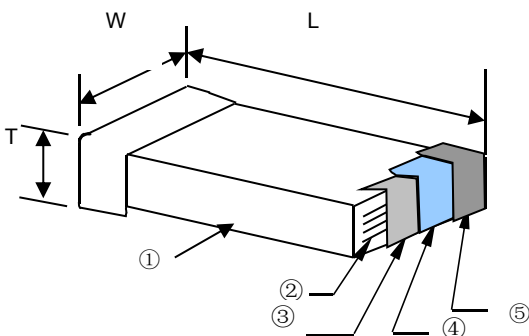
◆ Product Structure

NO	Name
①	Ceramic dielectric
②	Inner electrode
③	Substrate electrode
④	Nickel Layer
⑤	Tin Layer

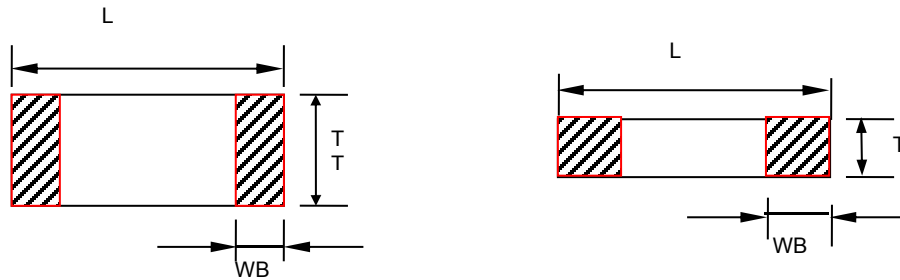
◆ Product Dimensions

Type		Dimensions (mm)			
British expression	Metric expression	L	W	T	WB
0402	1005	1.00±0.05	0.50±0.05	0.50±0.05	0.25±0.05
0603	1608	1.60±0.10	0.80±0.10	0.80±0.10	0.35±0.20
0805	2012	2.00±0.20	1.25±0.20	0.80±0.20 1.25±0.20	0.50±0.20
1206	3216	3.20±0.30	1.60±0.30	0.80±0.20 1.25±0.20 1.60±0.30	0.60±0.30
1210	3225	3.20±0.30	2.50±0.30	≤2.80	0.60±0.30
1808	4520	4.50±0.40	2.00±0.20	≤2.20	0.60±0.30
1812	4532	4.50±0.40	3.20±0.30	≤3.50	0.60±0.30
1825	4563	4.50±0.40	6.30±0.50	≤3.50	0.60±0.30
2211	5728	5.70±0.40	2.80±0.30	≤2.80	0.60±0.30
2220	5750	5.70±0.40	5.00±0.40	≤3.50	0.60±0.30

Note: 1、 The specific thickness of the product can read "capacity range and voltage "in this approval sheet.
 2、 We can design according to customer special requirements

◆ Temperature Coefficient /Characteristics

Dielectric	Reference Temperature Point	Temperature Coefficient	Operation Temperature Range
C0G	20°C	0±30 ppm/°C	-55°C~125°C
X7R	20°C	±15%	-55°C~125°C

Note: Nominal temperature coefficient and allowed tolerance of class I are decided by the changing of the capacitance between 20°C and 85°C. Nominal temperature coefficient of class II are decided by the temperature of 20°C.

◆ Capacitance Range and Operating Voltag

Dielectric	C0G								
	0402 (1.0mm*0.5mm)	0603 (1.6mm*0.8mm)			0805 (2.0mm*1.2mm)				
Dimension	100V	100V	200V	250V	100V	200V	250V	500V	1000V
Capacity/ Voltage	100V	100V	200V	250V	100V	200V	250V	500V	1000V
0.5pF									
1pF									
1.2pF									
1.5pF									
1.8pF									
2.0pF									
2.2pF									
2.7pF									
3.0pF									
3.3pF									
3.6pF									
3.9pF									
4.7pF									
5.0pF									
5.6pF									
6.8pF									
8.0pF									0.80±0.2 0
8.2pF									
10pF									
12pF									
15pF									
18pF									
22pF									
27pF									
33pF									
39pF									
47pF									
56pF									
68pF									
100pF	0.50±0.05								
120pF									
150pF									
180pF									
220pF									
270pF									
330pF									
390pF									
470pF									
560pF									
680pF									
1nF									
1.5nF									
1.8nF									
2.2nF									
2.7nF									
3.3nF									
4.7nF									
10nF									

Note: 1、【】 General thickness corresponds to the capacity, unit: mm
 2、We can design according to the customer requirements.

Dielectric	C0G							
Dimension	1206 (3.2mm*1.6mm)							
Capacity/ Voltage	100V	200V	250V	500V	630V	1000V	2000V	3000V
0.5pF								
1pF								
1.2pF								
1.5pF								
1.8pF								
2.0pF								
2.2pF								
2.7pF				0.80±0.20				
3.0pF								
3.3pF								
3.6pF								
3.9pF								
4.7pF								
5.0pF							1.00±0.20	
5.6pF								
6.8pF						1.00±0.20		
8.0pF								
8.2pF								
10pF					1.00±0.20			
12pF								
15pF								
18pF								
22pF								
27pF								
33pF								
39pF				1.00±0.20			1.25±0.20	
47pF								1.60±0.20
56pF								
68pF								
100pF								
120pF								
150pF		0.80±0.20						
180pF								
220pF								
270pF								
330pF								
390pF								
470pF								
560pF				1.25±0.20	1.25±0.20			
680pF	0.80±0.20					1.60±0.30		
1nF		1.00±0.20		1.60±0.30	1.60±0.30			
1.5nF								
1.8nF								
2.2nF								
2.7nF								
3.3nF								
4.7nF								
10nF								

Note: 1、【】 General thickness corresponds to the capacity, unit: mm

2、We can design according to the customer requirements.

Dielectric	COG									
	1210 (3.2mm*2.5mm)					1808 (4.2mm*5.0mm)				
Dimension	100V	200V	500V	1000V	2000V	500V	1000V	2000V	3000V	5000V
Capacity/ Voltage										
1pF										
1.2pF										
1.5pF										
1.8pF										
2.0pF										
2.2pF										
2.7pF										
3.0pF										
3.3pF										
3.6pF										
3.9pF										
4.7pF										
5.0pF										
5.6pF										
6.8pF										
8.0pF										
8.2pF										
10pF									1.60 ± 0.30	1.60 ± 0.30
12pF										
15pF										
18pF										
22pF										
27pF										
33pF										
39pF					1.25 ± 0.20					
47pF										
56pF										
68pF			1.25 ± 0.20	1.25 ± 0.20						
100pF	1.25 ± 0.20	1.25 ± 0.20	1.25 ± 0.20	1.25 ± 0.20	1.60 ± 0.30					2.0 ± 0.30
120pF										
150pF										
180pF										
220pF										
270pF				1.60 ± 0.30	1.80 ± 0.30					
330pF					2.0 ± 0.30				2.0 ± 0.30	
390pF										
470pF										
560pF	1.25 ± 0.20					1.60 ± 0.30				
680pF										
1nF									2.0 ± 0.30	
1.5nF			1.6 ± 0.30	2.0 ± 0.30						
1.8nF										
2.2nF			1.8 ± 0.30			1.80 ± 0.30				
2.7nF			2.0 ± 0.30							
3.3nF				2.5 ± 0.30						
4.7nF										
5.6nF										
6.8nF										
10nF										

Note: 1、【】 General thickness corresponds to the capacity, unit: mm

2、We can design according to the customer requirements.

Dielectric	COG											
	1812 (4.5mm*3.2mm)								1825			
Dimension	100V	200V	500V	630V	1000V	2000V	3000V	5000V	200V	630V	1KV	3KV
Capacity/ Voltage												
1.5pF												
1.8pF												
2.0pF												
2.2pF												
2.7pF												
3.0pF												
3.3pF												
3.6pF												
3.9pF												
4.7pF												
5.0pF												
5.6pF												
6.8pF												
8.0pF												
8.2pF												
10pF												
12pF												
15pF												
18pF												
22pF								1.6± 0.30				1.6± 0.30
27pF												
33pF												
39pF												
47pF												
56pF												
68pF												
100pF												
120pF												
150pF												
180pF												
220pF												
270pF												
330pF												
390pF												
470pF												
560pF												
680pF												
1nF												
1.5nF												
1.8nF												
2.2nF												
2.7nF												
3.3nF												
3.9nF												
4.7nF												
5.6nF												
6.8nF												
10nF												2.0± 0.30
15nF												1.6± 0.30
18nF												
22nF												
33nF												1.6± 0.30

Note: 1、【】 General thickness corresponds to the capacity, unit: mm

2、 We can design according to the customer requirements.

Dielectric	C0G										
Dimension	2220 (5.7mm*5.0mm)						2225 (5.7mm*6.3mm)				
	250V	500V	1000V	2000V	3000V	5000V	1000V	1500V	2000V	2500V	3000V
Capacity/ Voltage											
3.3pF											
3.6pF											
3.9pF											
4.7pF											
5.0pF											
5.6pF											
6.8pF											
8.0pF											
8.2pF											
10pF											
12pF											
15pF											
18pF											
22pF											
27pF											
33pF											
39pF											
47pF											
56pF											
68pF											
100pF											
120pF											
150pF											
180pF											
220pF											
270pF											
330pF											
390pF											
470pF											
560pF											
680pF											
1nF											
1.5nF											
1.8nF											
2.2nF											
2.7nF											
3.3nF											
3.9nF											
4.7nF											
5.6nF											
6.8nF											
10nF											
15nF											
18nF											
22nF											

Note: 1、【】 General thickness corresponds to the capacity, unit: mm
 2、 We can design according to the customer requirements.

A list of the specific voltage-specific capacitors of Class I capacitors

Dielectric	X7R										
	0402 (1.0mm*0.5m)	0603 (1.6mm*0.8mm)			0805 (2.0mm*1.2mm)						
Dimension	100V	100V	200V	250V	100V	200V	250V	500V	630V	1000V	2000V
Capacity/ Voltage	100V	100V	200V	250V	100V	200V	250V	500V	630V	1000V	2000V
100pF											
120pF											
150pF											
180pF											
220pF											
270pF											
330pF											
390pF											
470pF											
560pF											
680pF											
1nF											1.25 ±0.20
1.5nF											
1.8nF											
2.2nF											
2.7nF											
3.3nF											
4.7nF											
5.6nF											
10nF											
15nF											
18nF											
22nF											
33nF											
47nF											
56nF											
68nF											
100nF											
220nF											
330nF											
470nF											
680nF											
1μF											
2.2μF											
3.3μF											
4.7μF											
6.8μF											
10μF											

- Note: 1、【】 General thickness corresponds to the capacity, unit: mm
 2、 We can design according to the customer requirements.

Dielectric	X7R							
Dimension	1206 (3.2mm*1.6mm)							
Capacity/ Voltage	100V	200V	250V	500V	630V	1000V	2000V	2500V
100pF	0.80±0.20	0.80±0.20	0.80±0.20	0.80±0.20	1.25±0.20	1.25±0.20	1.25±0.20	1.25±0.20
120pF								
150pF								
180pF								
220pF								
270pF								
330pF								
390pF								
470pF								
560pF								
680pF								
1nF								
1.5nF								
1.8nF								
2.2nF								
2.7nF								
3.3nF								
4.7nF								
5.6nF								
6.8nF								
10nF								
15nF								
18nF								
22nF								
33nF								
47nF								
56nF								
68nF								
100nF								
220nF								
330nF								
470nF								
680nF								
1μF								
2.2μF								
3.3μF								
4.7μF								
6.8μF								
10μF								

Note: 1、【】 General thickness corresponds to the capacity, unit: mm
 2、We can design according to the customer requirements.

Dielectric	X7R														
	1210 (3.2mm*2.5mm)							1808 (4.2mm*5.0mm)							
Dimension	100V	200V	250V	500V	630V	1KV	2KV	100V	250V	500V	1KV	2KV	3KV	4KV	5KV
Capacity/ Voltage	100V	200V	250V	500V	630V	1KV	2KV	100V	250V	500V	1KV	2KV	3KV	4KV	5KV
100pF															
120pF															
150pF															
180pF															
220pF						1.25 ± 0.20	1.25 ± 0.20								
270pF															
330pF															
390pF															
470pF															
560pF															
680pF															
1nF							1.60 ± 0.30								
1.5nF															
1.8nF															
2.2nF															
2.7nF															
3.3nF															
4.7nF															
5.6nF															
6.8nF															
10nF			1.60 ± 0.30	1.25 ± 0.20											
15nF															
18nF	1.25 ±														
22nF	± 0.20														
33nF															
47nF		1.25 ± 0.20		1.60 ± 0.30	2.0 ± 0.30					1.60 ± 0.30					
56nF					1.60 ± 0.30										
68nF															
100nF															
220nF			2.5 ± 0.30												
330nF	1.60 ± 0.30														
470nF															
680nF															
1μF															
2.2μF	2.5 ± 0.30														
3.3μF															
4.7μF															
6.8μF															
10μF															

Note: 1、【】 General thickness corresponds to the capacity, unit: mm
 2、We can design according to the customer requirements.

Dielectric	X7R									
Dimension	1812 (4.5mm*3.2mm)									
Capacity/ Voltage	100V	200V	250V	500V	630V	1KV	2KV	3KV	4KV	5KV
100pF										
120pF										
150pF										
180pF										
220pF										
270pF										
330pF										
390pF										
470pF										
560pF										
680pF										
1nF										
1.5nF										
1.8nF										
2.2nF										
2.7nF										
3.3nF										
4.7nF										
5.6nF										
6.8nF										
10nF										
15nF										
18nF										
22nF										
33nF										
47nF										
56nF										
68nF										
100nF										
220nF										
330nF										
470nF										
680nF										
1μF										
2.2μF										
3.3μF										
4.7μF										
6.8μF										
10μF										

Note: 1、【】 General thickness corresponds to the capacity, unit: mm

2、We can design according to the customer requirements.

Dielectric	X7R								
	1825 (4.5mm*6.3mm)						2211 (5.7mm*2.8mm)		
Dimension	200V	250V	500V	630V	1000V	2000V	3000V	3000V	5000V
Capacity/ Voltage									
100pF									
120pF									
150pF									
180pF									
220pF									
270pF									
330pF									
390pF									
470pF									1.6±0.3
560pF									
680pF									
1nF									
1.5nF									
1.8nF									
2.2nF								1.6±0.3	
2.7nF									
3.3nF									
3.9nF									
4.7nF						1.6±0.3		1.8±0.3	
5.6nF								2.0±0.3	
6.8nF									
10nF									
15nF									
18nF									
22nF					1.6±0.3				
33nF									
47nF									
56nF									
68nF									
100nF	1.6±0.3		1.6±0.3		2.0±0.3				
120nF									
150nF				1.6±0.3					
220nF									
330nF									
470nF									
680nF									
1 μ F									
2.2 μ F									
3.3 μ F									
4.7 μ F									
6.8 μ F									
10 μ F		2.0±0.3							

Note: 1、【】 General thickness corresponds to the capacity, unit: mm

2、We can design according to the customer requirements.

Dielectric	X7R										
Dimension	2220 (5.7mm*6.3mm)										
Capacity/ Voltage	100V	200V	250V	500V	630V	1000V	2000V	2500V	3000V	4000V	5000V
100pF											
120pF											
150pF											
180pF											
220pF											
270pF											
330pF											
390pF											
470pF											
560pF											
680pF											
1nF											
1.5nF											1.60 ±0.30
1.8nF											
2.2nF											
2.7nF											
3.3nF											
3.9nF											
4.7nF											
5.6nF											
6.8nF											
8.2nF											
10nF											
15nF											
18nF											
22nF											
33nF											
47nF											
56nF											
68nF											
100nF											
120nF											
150nF											
220nF											
330nF											
470nF											
680nF											
1μF											
2.2μF											
3.3μF											
4.7μF											
6.8μF											
10μF											

Note: 1、【】 General thickness corresponds to the capacity, unit: mm

2、We can design according to the customer requirements.

Dielectric	X7R									
Dimension	2225 (5.7mm*5.0mm)									
Capacity/ Voltage	100V	200V	250V	500V	1000V	1500V	2000V	3000V	4000V	5000V
100pF										
120pF										
150pF										
180pF										
220pF										
270pF										
330pF										
390pF										
470pF										
560pF										
680pF										
1nF										
1.5nF								1.60 ±0.3		1.60 ±0.3
1.8nF										
2.2nF									1.8±0.3	
2.7nF					1.60 ±0.3					
3.3nF										
3.9nF										
4.7nF										
5.6nF								1.60 ±0.3		
6.8nF										
10nF										
15nF										
18nF			1.60 ±0.30						1.8±0.3	
22nF								1.8±0.3		
33nF					1.60 ±0.30			2.0±0.3		
47nF								1.8±0.3		
56nF										
68nF					1.8±0.3			2.0±0.3		
100nF							2.0±0.3			
120nF					2.0±0.3					
150nF	1.60 ±0.30									
220nF										
330nF										
470nF		1.60 ±0.30								
680nF					2.0±0.3					
1μF					2.5±0.3					
2.2μF			2.0 ±0.30							
3.3μF										
4.7μF										
6.8μF										
10μF										

Note: 1、【】 General thickness corresponds to the capacity, unit: mm
 2、We can design according to the customer requirements.

◆ Measurement method of dielectric withstanding voltage for high voltage MLCC:

Rated voltage range	Measuring Method
100V≤Vr<500V	Force 200%Rated voltage for 5 second. Max..current should not exceed 50 mA.
500V≤Vr≤1000V	Force 150%Rated voltage for 5 second. Max..current should not exceed 50 mA.
1000V<Vr≤2000V	Force 120%Rated voltage for 5 seconds. Max..current should not exceed 50 mA.
2000V<Vr≤5000V	Force 120%Rated voltage for 5 seconds. Max..current should not exceed 10 mA.

◆ Reliability Test

Item	Technical Specification		Test Method and Remarks		
			Capacitance	Measuring Frequency	Measuring Voltage
Capacitance	Class I	Should be within the specified tolerance.	≤1000pF	1MHz±10%	1.0±0.2Vrms
			>1000 pF	1KHz±10%	
	Class II	Should be within the specified tolerance.	Test Temperature: 25℃±3℃ Test Frequency: 1KHz±10% Test Voltage: 1.0±0.2Vrms		
(DF, tanδ) Dissipation Factor	Class I	DF	Capacitance	Measuring Frequency	Measuring Voltage
		≤1/ (400+20C) ≤0.1%	C<30 pF C≥30pF	1MHz±10%	1.0±0.2Vrms
	Class II	≤2.5%	Test Temperature: 25℃±3℃ Test Frequency: 1KHz±10% Test Voltage: 1.0±0.2Vrms		
(IR) Insulation Resistance	Class I	C≤10 nF, Ri≥50000MΩ C>10 nF, Ri•Cr≥500S	Measuring Voltage: Rated Voltage (Max 500V) Duration: 60±5s Test Humidity: ≤75% Test Temperature: 25℃±3℃ Test Current: ≤50mA		
	Class II	C≤25nF, Ri≥10000MΩ C>25nF, Ri•Cr>100S			
Solderability	At least 95% of the terminal electrode is covered by new solder. Visual Appearance: No visible damage.		Preheating conditions:80 to 120℃; 10~30s.		
			Pb-Sn soldering Solder Temperature:235±5℃ Duration: 2±0.5s		Lead-free soldering Solder Temperature: 245±5℃ Duration: 2±0.5s

◆ Reliability Test

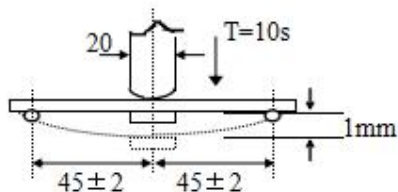
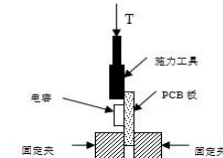
Item	Technical Specification	Test Method and Remarks																					
Resistance to Soldering Heat	<table border="1"> <thead> <tr> <th>Item</th> <th>I</th> <th>II</th> </tr> </thead> <tbody> <tr> <td>$\Delta C/C$</td> <td>$\leq \pm 2.5\%$ 或 $\pm 0.25\text{pF}$, whichever is larger</td> <td>$\pm 15\%$</td> </tr> <tr> <td>DF</td> <td colspan="2">Same to initial value.</td> </tr> <tr> <td>IR</td> <td colspan="2">Same to initial value.</td> </tr> <tr> <td colspan="3">Appearance : No visible damage. At least 95% of the terminal electrode is covered by new solder.</td> </tr> </tbody> </table>	Item	I	II	$\Delta C/C$	$\leq \pm 2.5\%$ 或 $\pm 0.25\text{pF}$, whichever is larger	$\pm 15\%$	DF	Same to initial value.		IR	Same to initial value.		Appearance : No visible damage. At least 95% of the terminal electrode is covered by new solder.			Preheating conditions: 100 to 200°C; 60-120s. Solder Temperature: 265±5°C Duration: 10±1s Clean the capacitor with solvent and examine it with a 10X(min.) microscope. Recovery Time: 24±2h Recovery condition: Room temperature						
	Item	I	II																				
	$\Delta C/C$	$\leq \pm 2.5\%$ 或 $\pm 0.25\text{pF}$, whichever is larger	$\pm 15\%$																				
	DF	Same to initial value.																					
	IR	Same to initial value.																					
Appearance : No visible damage. At least 95% of the terminal electrode is covered by new solder.																							
Resistance to Flexure of Substrate (Bending Strength)	Appearance: No visible damage.	Test Board: PCB Warp: 1mm Speed: 1mm/sec. Unit: mm The measurement should be made with the board in the bending position. 																					
	Class I : $\leq \pm 5\%$ or $\pm 0.5\text{pF}$, whichever is larger.																						
	Class II : $\leq \pm 10\%$																						
Temperature Cycle	<table border="1"> <thead> <tr> <th>Item</th> <th>COG</th> <th>X7R</th> </tr> </thead> <tbody> <tr> <td>$\Delta C/C$</td> <td>$\leq \pm 1\%$ or $\pm 1\text{pF}$, whichever is larger</td> <td>-15% ~ +15%</td> </tr> </tbody> </table>	Item	COG	X7R	$\Delta C/C$	$\leq \pm 1\%$ or $\pm 1\text{pF}$, whichever is larger	-15% ~ +15%	Preheating conditions: up-category temperature, 1h Recovery time: 24±1h Initial Measurement Cycling Times: 5 times, 1 cycle, 4 steps: <table border="1"> <thead> <tr> <th>Step</th> <th>(Temperature)</th> <th>(Time)</th> </tr> </thead> <tbody> <tr> <td>1</td> <td>(Low- category temp.): (COGX7R: -55°C)</td> <td>30min</td> </tr> <tr> <td>2</td> <td>(Normal temp.) : +20°C</td> <td>2~3min</td> </tr> <tr> <td>3</td> <td>(Up- category temp.) (COG/X7R: +125°C)</td> <td>30min</td> </tr> <tr> <td>4</td> <td>(Normal temp.) : +20°C</td> <td>2~3min</td> </tr> </tbody> </table> Recovery time after test: 24±2h	Step	(Temperature)	(Time)	1	(Low- category temp.): (COGX7R: -55°C)	30min	2	(Normal temp.) : +20°C	2~3min	3	(Up- category temp.) (COG/X7R: +125°C)	30min	4	(Normal temp.) : +20°C	2~3min
	Item	COG	X7R																				
	$\Delta C/C$	$\leq \pm 1\%$ or $\pm 1\text{pF}$, whichever is larger	-15% ~ +15%																				
Step	(Temperature)	(Time)																					
1	(Low- category temp.): (COGX7R: -55°C)	30min																					
2	(Normal temp.) : +20°C	2~3min																					
3	(Up- category temp.) (COG/X7R: +125°C)	30min																					
4	(Normal temp.) : +20°C	2~3min																					
No visible damage.																							
Termination Adhesion	No visible damage.	As shown in the picture , Slowly apply a T force to the porcelain body on the side of the capacitor and hold for 60+1 seconds. <table border="1"> <thead> <tr> <th>规格</th> <th>施加力 T</th> </tr> </thead> <tbody> <tr> <td>≤ 0402</td> <td>2N</td> </tr> <tr> <td>≥ 0603</td> <td>5N</td> </tr> </tbody> </table> 	规格	施加力 T	≤ 0402	2N	≥ 0603	5N															
规格	施加力 T																						
≤ 0402	2N																						
≥ 0603	5N																						

◆ Reliability Test

Item	Technical Specification			Test Method and Remarks
Humidity load	$\Delta C / C$	I 类	$\pm 7.5\%$ or $\pm 0.75pF$, whichever is larger.	※ Pretreatment (Class II) : After preheating at $140^{\circ}C \sim 150^{\circ}C$ for $1h \pm 10min$, place at room temperature for $24 \pm 2h$. Temperature: $40 \pm 2^{\circ}C$ Humidity: $90 \sim 95\%RH$ Voltage: Rated Voltage Duration: 500h Recovery Time: $24h \pm 2h$ Class 2: $0201 \geq 47nF$, $0402 \geq 33nF$, $0603 \geq 1\mu F$, $0805 \geq 4.7\mu F$, $1206 \geq 10\mu F$ product need to keep in $150^{\circ}C$, 1h after the test, and measurement to be made after being kept at room temperature for $24 \pm 2h$.
		II 类	$-12.5\% \sim +12.5\%$	
	DF	Not more than twice of initial value.		
	IR	I 类	$R_i \geq 5000M\Omega$ 或 $R_i \cdot C_R \geq 50S$ whichever is smaller.	
		II 类	$R_i \geq 1000M\Omega$ 或 $R_i \cdot C_R \geq 10S$ whichever is smaller.	
	Appearance: No visible damage.			
Life Test	$\Delta C / C$	I 类	$\leq \pm 3\%$ 或 $\pm 0.3pF$, whichever is larger.	※ Pretreatment (Class II) : After preheating at $140^{\circ}C \sim 150^{\circ}C$ for $1h \pm 10min$, place at room temperature for $24 \pm 2h$. Applied Voltage: $100V \leq \text{Rated Voltage} \leq 200V$: 1.5 Multiple $200V < \text{Rated Voltage} \leq 500V$: 1.3 Multiple $500V < \text{Rated Voltage}$: 1.2 Multiple Duration: 1000h Temperature: $125^{\circ}C$ (C0G, X7R) Charge/Discharge Current: 50mA max. Recovery Time: $24h \pm 2h$ Class 2: $0201 \geq 47nF$, $0402 \geq 33nF$, $0603 \geq 1\mu F$, $0805 \geq 4.7\mu F$, $1206 \geq 10\mu F$ product need to keep in $150^{\circ}C$, 1h after the test, and measurement to be made after being kept at room temperature for $24 \pm 2h$.
		II 类	$-20\% \sim +20\%$	
	DF	Not more than twice of initial value.		
	IR	I 类	$R_i \geq 4000M\Omega$ 或 $R_i \cdot C_R \geq 40S$ whichever is smaller.	
		II 类	$R_i \geq 2000M\Omega$ 或 $R_i \cdot C_R \geq 50S$ whichever is smaller.	
	Appearance: No visible damage.			

Note : Pretreatment (only for class2 capacitor) : Pretreatment (only for class2 capacitor) is a method to treat the capacitor before measurement. First, place the capacitor in the up-category temperature or other specified higher temperature environment for 1hour. Then recovery the capacitor at standard pressure conditions for 24 ± 1 hours.

◆ **Package**

* Paper taping

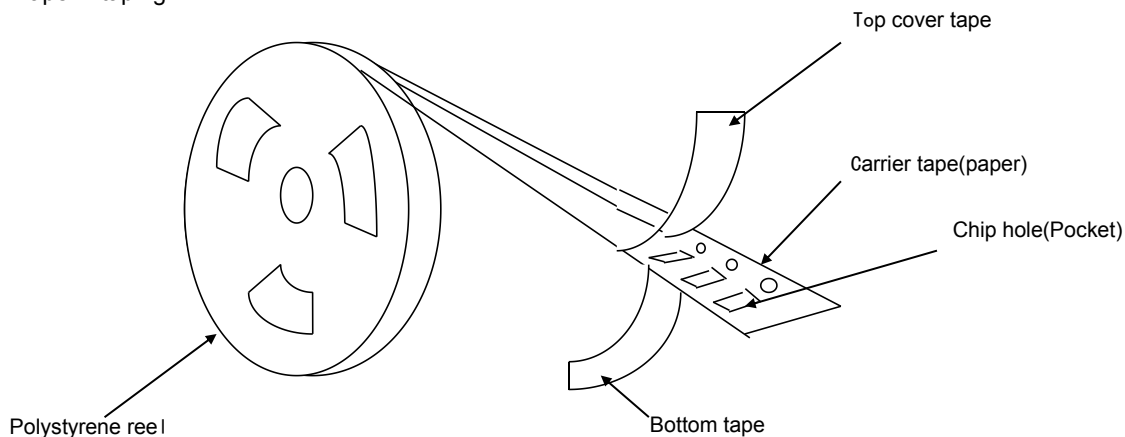

* Dimensions of paper taping for 0402 type

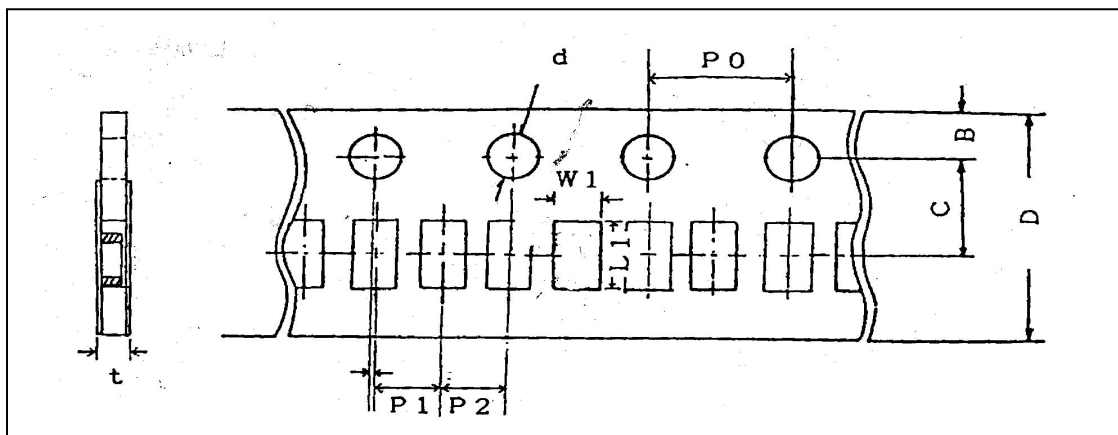

Code	W1	L1	D	C	B	P1	P2	P0	d	t
0402	0.65 ±0.10	1.15 ±0.10	8.00 ±0.10	3.50 ±0.05	1.75 ±0.10	2.00 ±0.05	2.00 ±0.05	4.00 ±0.10	1.50 -0/+0.10	0.80 Below

* Dimensions of paper taping for 0603, 0805, 1206 types.

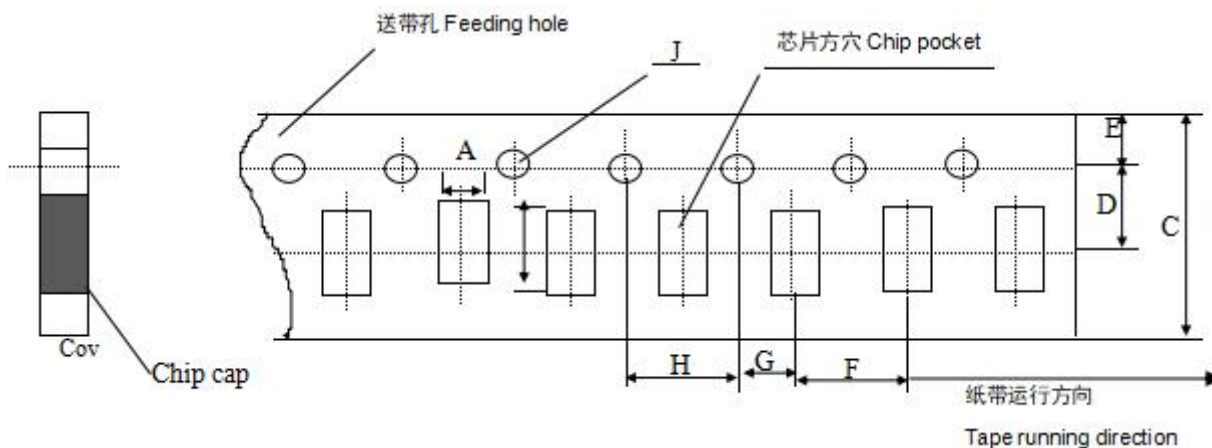

Unit: mm

Code paper size	A	B	C	D*	E	F	G*	H	J	T
0603	1.10 ±0.10	1.90 ±0.10	8.00 ±0.10	3.50 ±0.05	1.75 ±0.10	4.00 ±0.10	2.00 ±0.10	4.00 ±0.10	1.50 -0/+0.10	1.10 Max
0805	1.45 ±0.15	2.30 ±0.15	8.00 ±0.15	3.50 ±0.05	1.75 ±0.10	4.00 ±0.10	2.00 ±0.10	4.00 ±0.10	1.50 -0/+0.10	1.10 Max
1206	1.80 ±0.20	3.40 ±0.20	8.00 ±0.20	3.50 ±0.05	1.75 ±0.10	4.00 ±0.10	2.00 ±0.10	4.00 ±0.10	1.50 -0/+0.10	1.10 Max

Note: The place with "*" means where needs exactly dimensions.

* Embossed taping

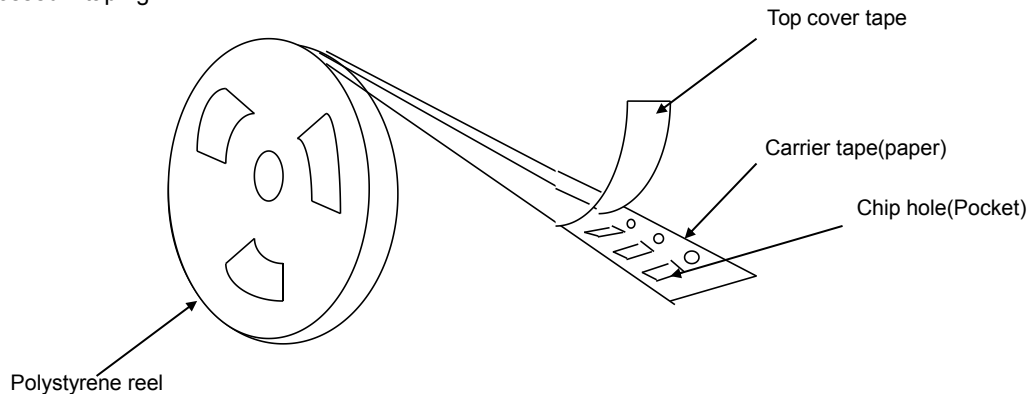

* Dimensions of embossed taping for 0805~2225 type

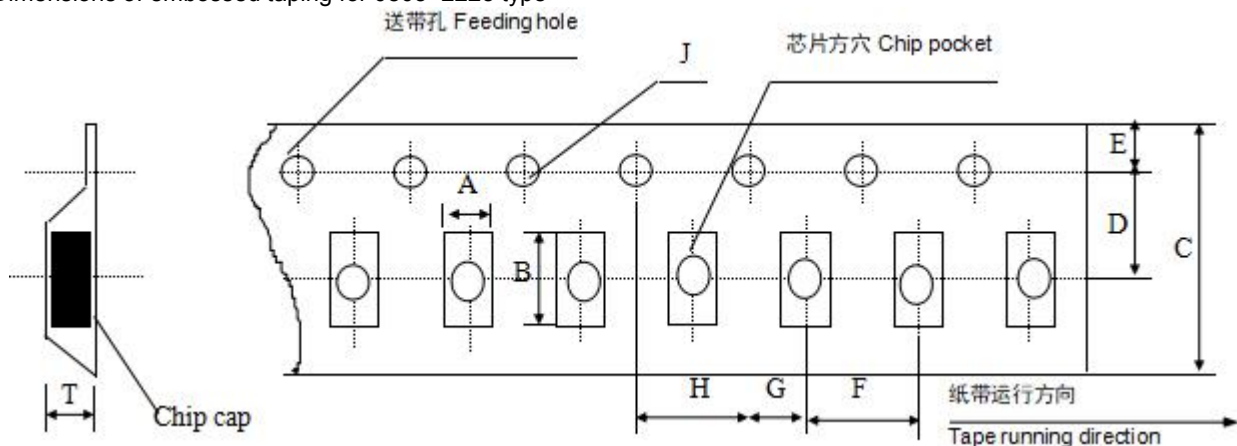

Code Tape size	A	B	C	D*	E	F	G*	H	J	T
0805	1.55 ±0.20	2.35 ±0.20	8.00 ±0.20	3.50 ±0.05	1.75 ±0.10	4.00 ±0.10	2.00 ±0.10	4.00 ±0.10	1.50 -0/+0.10	1.50 Max
1206	1.95 ±0.20	3.60 ±0.20	8.00 ±0.20	3.50 ±0.05	1.75 ±0.10	4.00 ±0.10	2.00 ±0.10	4.00 ±0.1	1.50 -0/+0.10	1.85 Max
1210	2.70 ±0.10	3.42 ±0.10	8.00 ±0.10	3.50 ±0.05	1.75 ±0.10	4.00 ±0.10	2.00 ±0.05	4.00 ±0.10	1.55 -0/+0.10	3.2 Max
1808	2.20 ±0.10	4.95 ±0.10	12.00 ±0.10	5.50 ±0.05	1.75 ±0.10	4.00 ±0.10	2.00 ±0.05	4.00 ±0.10	1.50 -0/+0.10	3.0 Max
1812	3.66 ±0.10	4.95 ±0.10	12.00 ±0.10	5.50 ±0.05	1.75 ±0.10	8.00 ±0.10	2.00 ±0.05	4.00 ±0.10	1.55 -0/+0.10	4.0 Max
2211	3.0 ±0.1	6.0 ±0.1	12.00 ±0.10	5.50 ±0.05	1.75 ±0.10	8.00 ±0.10	2.00 ±0.05	4.00 ±0.10	1.55 -0/+0.10	1.8 ±0.10
2211/2220/2225	6.2 ±0.1	6.7 ±0.1	12.00 ±0.10	5.50 ±0.05	1.75 ±0.10	8.00 ±0.10	2.00 ±0.05	4.00 ±0.10	1.55 -0/+0.10	2.4 ±0.10

Note: The place with "*" means where needs exactly dimensions.

* Structure of leader part and end part of the carrier paper

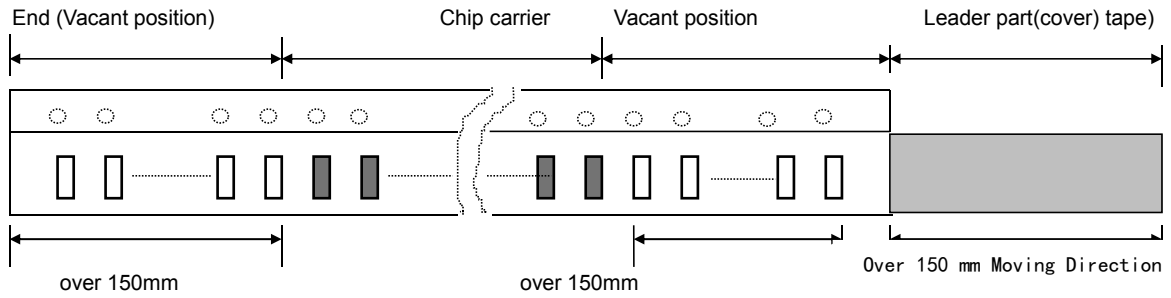

* Reel dimensions (unit: mm)

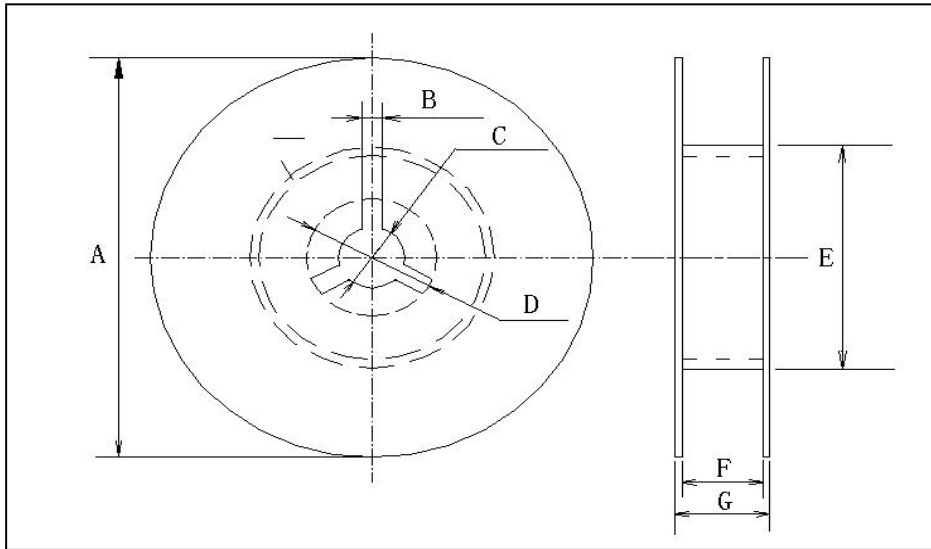

	A	B	C	D	E	F	G
7'REEL	$\phi 178 \pm 2.0$	3.0	$\phi 13 \pm 0.5$	$\phi 21 \pm 0.8$	$\phi 50$ 或更大 $\phi 50$ or more	10.0 ± 1.5	12max

* Taping specification: top tape peeling strength

Paper Taping

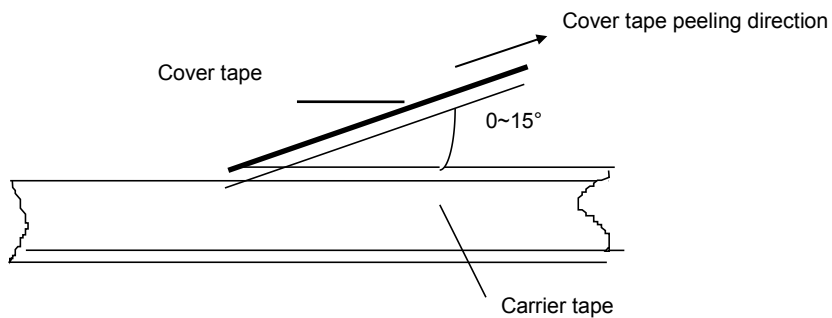

Embossed Taping

Cover tape peeling direction

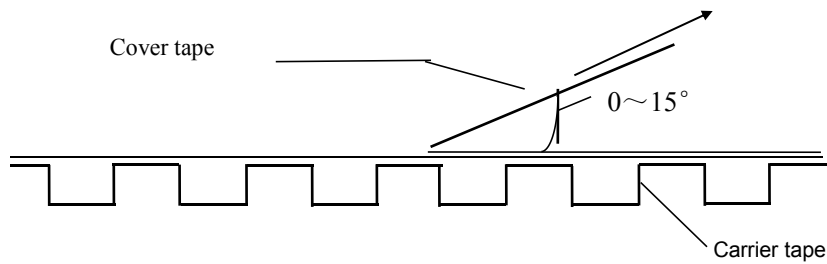
 Standard: $0.1N < \text{peeling strength} < 0.7N$

No paper dirty remains on the scotch when peeling, and sticks to top and bottom tape.

*Bulk Case Package

(unit) :mm

Symbol	A	B	T	C	D	E
Dimension	6.80±0.10	8.80±1.00	12.00±0.10	15.00+0.10/-0	2.00+0/-0.10	4.70±0.10
Symbol	F	W	G	H	L	I
Dimension	31.50+0.20/-0	36.00+0/-0.20	19.00±0.35	7.00±0.35	110.00±0.70	5.00±0.35

* Packing Quantity

(SIZE)	(Package Style & Quantity) unit: pcs				
	(EPT)	(PT)	(ET)	(BC)	(BP)
0402	-----	10000	-----	20000	5000
0603	-----	4000	-----	15000	5000
0805	-----	4000	3000	10000	5000
1206	-----	4000	T≤1.35mm 3000 T>1.35mm 2000	5000	5000
1210	-----	-----	T≤1.80mm 2000 T>1.80mm 1000	-----	2000
1808	-----	-----	2000	-----	2000
1812	-----	-----	T≤1.85mm 1000 T>1.85mm 500	-----	2000
2211、2220、2225	-----	-----	500	-----	500

Note: We can choose packing style and quantity can be according to the customer's requirement.

*Outer packing

The first package
 Quantity: 10 reels

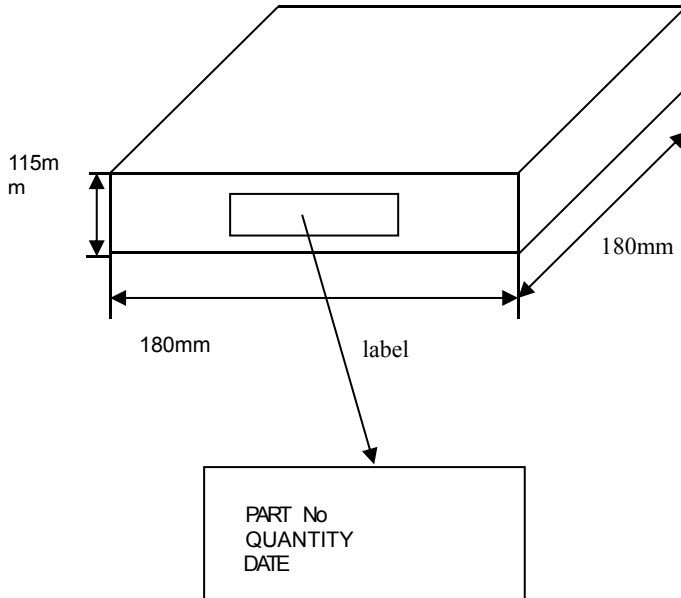

The second package
 Quantity: 6 cases

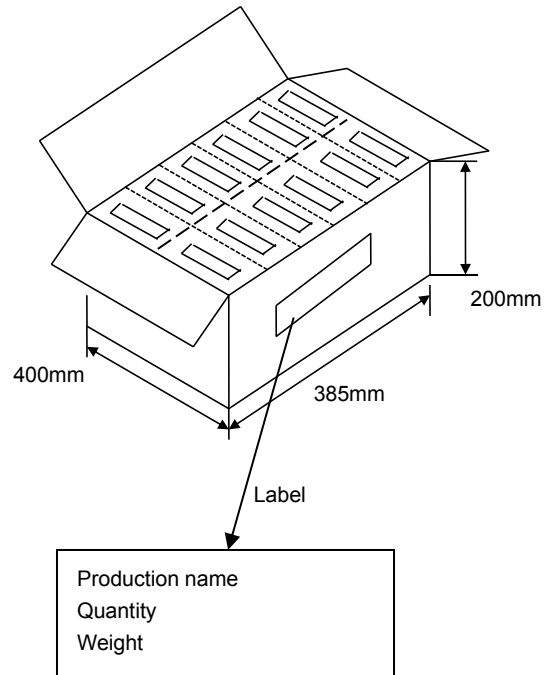

◆ **Storage Methods**

The guaranteed period for solderability is 12 months (Under deliver package condition).

* Storage conditions:

Temperature 5~40℃

Relative Humidity 20~70%

◆ **Precautions For Use**

The Multi-layer Ceramic Capacitors (MLCC) may fail in a short circuit mode in an open circuit mode when subjected to severe conditions of electrical environment and / or mechanical stress beyond the specified "rating" and specified "conditions" in the specification, which will result in burn out, flaming or glowing in the worst case. Following "precautions for "safety" and Application Notes shall be taken in your major consideration. If you have a question about the precautions for handling, please contact our engineering section or factory.

* Soldering Profile

To avoid the crack problem by sudden temperature change, follow the temperature profile in the adjacent graph (refer to the graph in the enclosure page).

* Manual Soldering

Manual soldering can pose a great risk of creating thermal cracks in capacitors. The hot soldering iron tip comes into direct contact with the end terminations, and operator's carelessness may cause the tip of the soldering iron to come into direct contact with the ceramic body of the capacitor. Therefore the soldering iron must be handled carefully, and pay much attention to the selection of the soldering iron tip and temperature contact of the tip.

* Optimum Solder Amount for Reflow Soldering

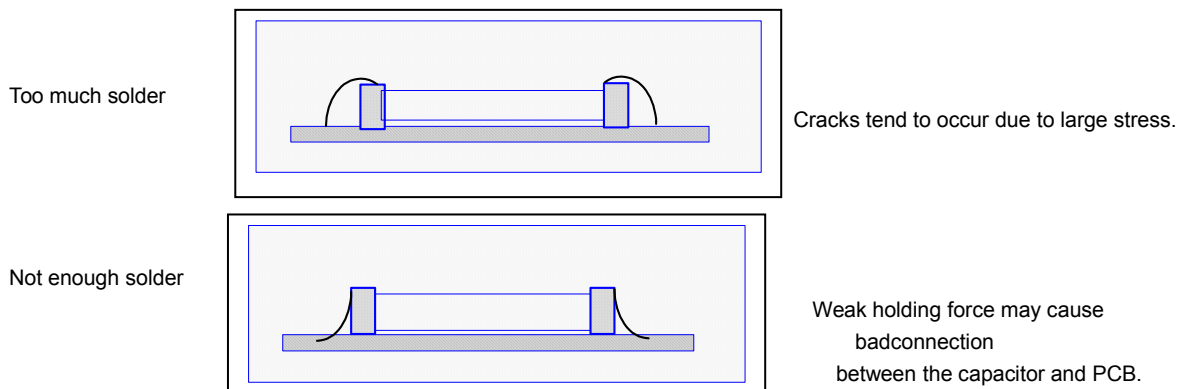

* Recommended Soldering amounts

The optimal solder fillet amounts for re-flow soldering

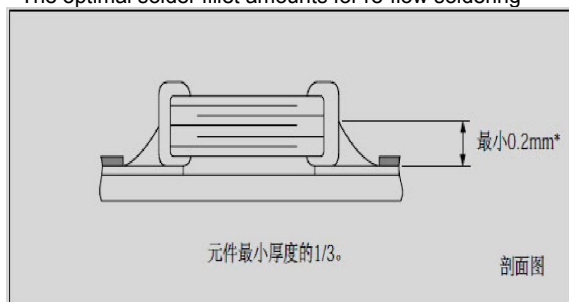

The optimal solder fillet amounts for wave soldering

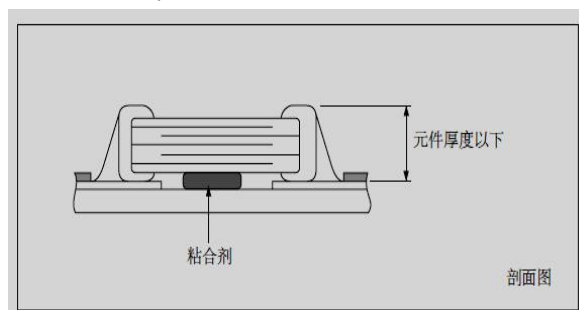

The optimal solder fillet amounts for reworking by using soldering iron

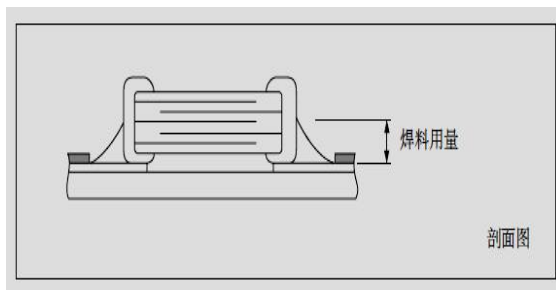

* Recommended Soldering Method

Size	Temperature Characteristics	RatedVoltage	Capacitance	Soldering Method
0402	C0G	/	/	R
	X7R	/	/	R
0603	C0G	/	/	R/W
	X7R	/	C≥1uf	R/W

*** Recommended Soldering Method**

Size	Temperature Characteristics	Rated Voltage	Capacitance	Soldering Method
0805	C0G	/	/	R/W
	X7R	/	$C \geq 4.7\mu\text{f}$	R
			$C < 4.7\mu\text{f}$	R/W
1206	C0G	/	/	R/W
	X7R	/	$C \geq 10\mu\text{f}$	R
			$C < 10\mu\text{f}$	R/W
≥ 1210	C0G	/	/	R
	X7R	/	/	R

Soldering method: R— Reflow Solering W— Wave Soldering

◆ The temperature profile for soldering
*** (Re-flow soldering)**

	Pb-Sn soldering	Lead-free soldering
Peak temperature	230°C~250°C	240°C~260°C

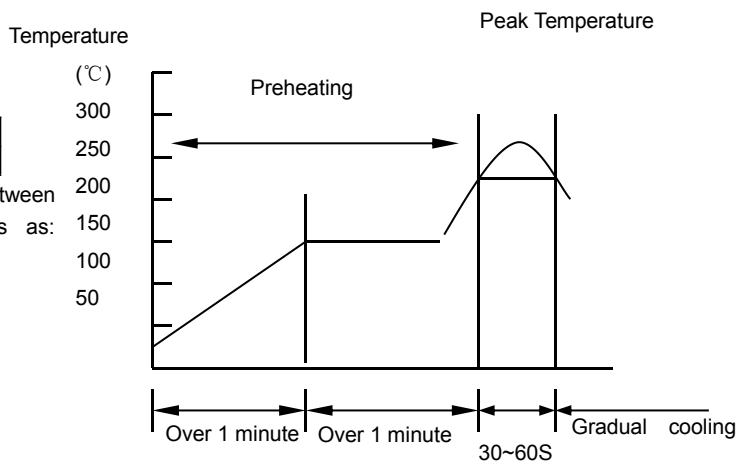
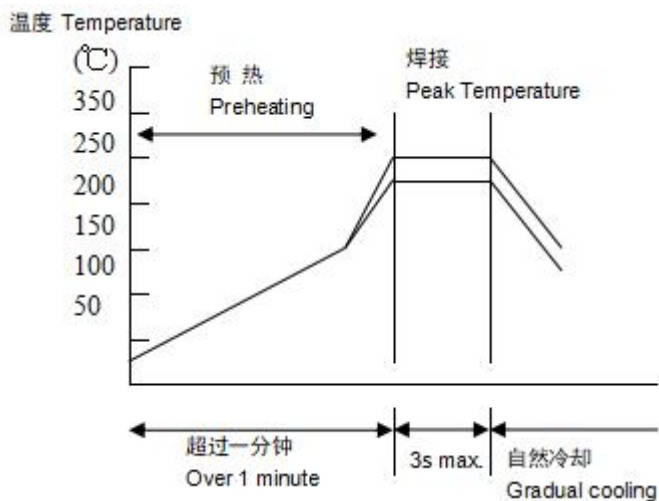
 While in preheating, please keep the temperature difference between soldering temperature and surface temperature of chips as: $T \leq 150^\circ\text{C}$.

*** (Wave soldering)**

	Pb-Sn soldering	Lead-free soldering
Peak temperature	230°C~260°C	240°C~270°C

 While in preheating, please keep the temperature difference between soldering temperature and surface temperature of chips as: $T \leq 150^\circ\text{C}$.

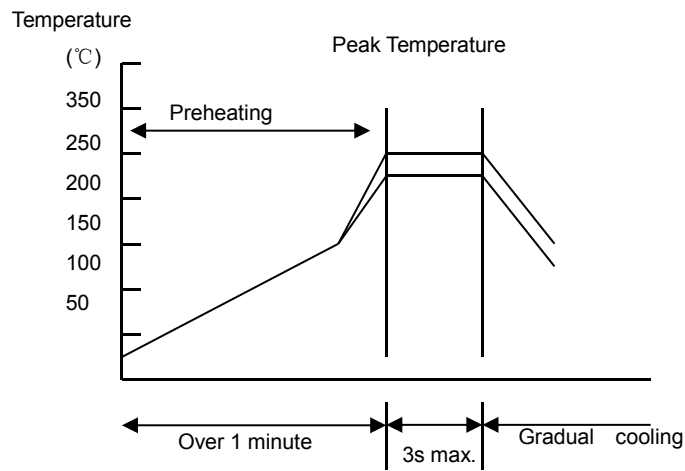
*
Hand soldering



Conditions:

Preheating	Temperature of soldering iron head	Power of soldering iron	Diameter of soldering iron head	Soldering time	Solder paste amount	Restricted conditions
$\Delta \leq 130^{\circ}\text{C}$	Highest temperature: 350°C	20W at the highest	1mm recommended	3s at the longest	$\leq 1/2$ chip thickness	Please avoid the direct contact between soldering iron head and ceramic components

*The latest version of the content shall prevail